



Insulating Shrouds

Hyena Insulating Shrouds.

Many jobs need a shroud where installations back onto the outside walls of the building or near insulation.

Ours has been designed to suit most Major Australian electrical wiring device brands.

**Suits most
MAJOR
Australian
Electrical Wiring
Device Brands**



100 Years of Gerard Electrical Tradition



Order Code

HYSHR



Order Code

HYSHRS
(SHALLOW)



Order Code

HYSHRW
(WIDE)

Suitable for Flat Cat



Available Now through your Electrical Wholesaler

Another range extension from Trader, Hyena Insulating Shrouds are ready for use by the Australian Electrical Contractor. The Trader shrouds are universal as possible across the market with as many mounting accessories, switches and sockets. We have also made this shroud from a plastic which is as friendly as possible on your hands when installing and as easy to use as possible when performing any cut outs and cable entry points required. It has been manufactured to be more economical than others on the market.

HYSHR

Internal dimensions:

- Length 75.6 mm
- Width 50.6 mm
- Depth 49 mm

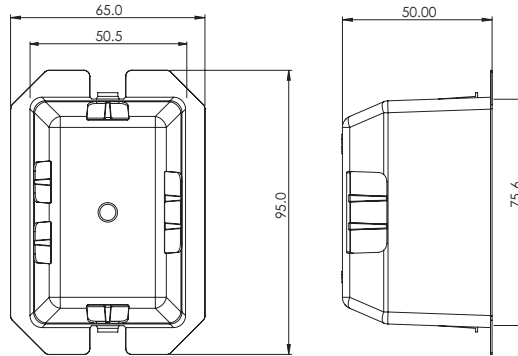

HYSHRS (Shallow)

Internal dimensions:

- Length 76mm
- Width 51mm
- Depth 39mm

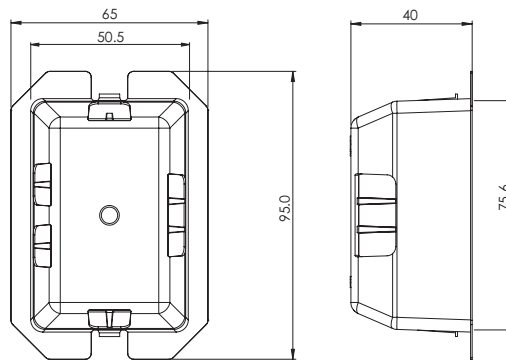

HYSHRW (Wide)

Ideally suited to fit the Flat Cat Range

Internal dimensions:

- Length 73.8 mm
- Width 50.8 mm
- Depth 49.1 mm

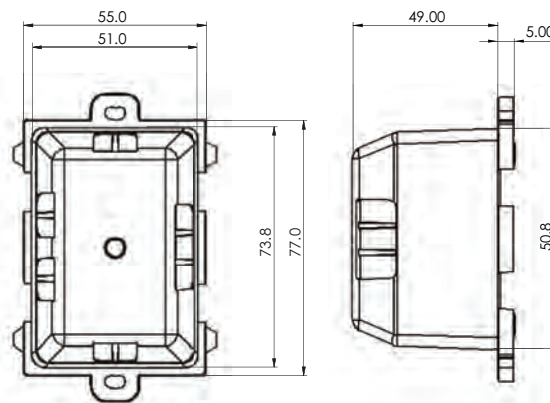

Cross Reference Chart

TRADER	*Clipsal
HYSHR	90B
HYSHRS	90B
HYSHRW	90BI



TRADER®
100 Years of Gerard Electrical Tradition

