

PUMA ™



4 Switch Key Tag Puma Switch Vertical 6 Gang Grid with 4 Switch Key Tag

- Hospitality/Occupancy key tag access switch plate.
- Rated 16A/10AX per switch mechanism (4 in plate).
- 2 additional blank apertures for retrofitting additional switches or neon indicators where necessary.
- Ideal for use in hotels, site building access and other areas where the use of facilities needs to be controlled.
- 84mm mounting.
- Developed in the robust Puma Vandal Proof Series.
- Wall plate overall height 24mm or 33mm with key inserted.
- Requires 120mm below the wall plate to allow the key to be inserted.



PUSWV6GKT4



PUSWKT

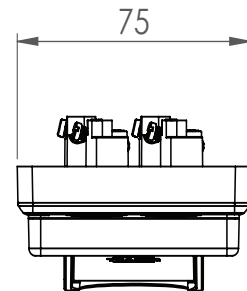
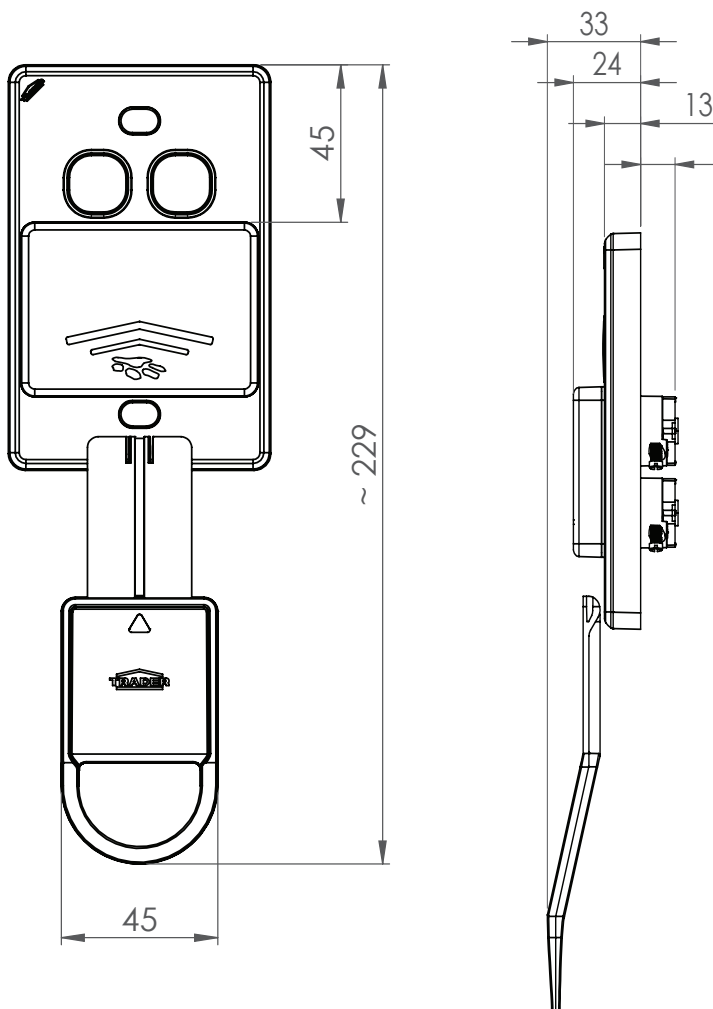

NON REMOVABLE COVER



SECURITY SCREWS

